

Lithium Niobate Modulator Transmitter Module 30 GHz

4 operation modes, up to 40 mW

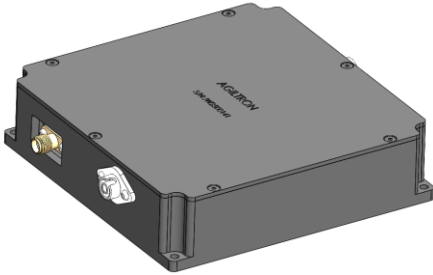

Features

- 30 GHz S21 bandwidth modulator
- 1527 nm to 1567 nm LD wavelength range
- Automatic Bias Control w/ 4 mode operation
- PM Output (customizable option)
- High Extinction Ratio (>25 dB)

Applications

- Analog photonics
- 35 GHz RFoF transmission
- RF/IF signal distribution
- Satellite communication
- Optical communications to 25 Gb/s
- Picosecond pulse generation



The LNTM is a high-performance laser transmitter/converter module designed for analog photonics applications spanning 10 MHz to 30 GHz, featuring high extinction >20dB. It integrates a lithium niobate waveguide modulator, a distributed feedback (DFB) laser, and an automatic bias controller. The automatic bias controller eliminates drifts caused by environmental temperature variations or extended operation, having four operation modes: Q+ and Q- for quadrature points with positive or negative slopes, ideal for linear analog modulation, and Min and Max for minimum or maximum points, optimized for pulse generation in digital modulation. Powered by a single 12V DC supply, the LNTM provides a versatile, reliable solution for RF-over-fiber (RFoF) system integration, enabling precise and stable signal transmission. Further integrating a >20dBm RF broadband modulator driver is an option.

Specifications

Parameter	Min	Typical	Max	Unit
Operating Wavelength	1520		1610	nm
Operating Frequency Range (@3dB)	0.01	30	35	GHz
Input RF Voltage			27	dBm
RF Return Loss		> 15		dB
Laser Power Level		20	40	mW
Extinction Ratio		25		dB
Modulator Voltage (no amplifier)	7 V typ. @ 30 GHz			V
Operating Temperature (standard)	-30		+60	°C
Storage Temperature	-60		+90	°C
Power Supply Requirements	+ 12 V DC, 1 A typ.			
Optical Connectors	FC/APC			
RF Input Connector	GPPO or V connector			
Remote Control	USB/RS232			
Analog Link Performance				
IIP3 @ 30 GHz		32		dBm
1 dB Compression Point @ 30 GHz		16.5		dBm

Note: The specifications provided are for general applications with a cost-effective approach. If you need to narrow or expand the tolerance, coverage, limit, or qualifications, please [click this link](#):

Rev 01/14/25

Lithium Niobate Modulator Transmitter Module 14 GHz

4 operation modes, up to 40 mW

DATASHEET

Mechanical Dimension (mm)

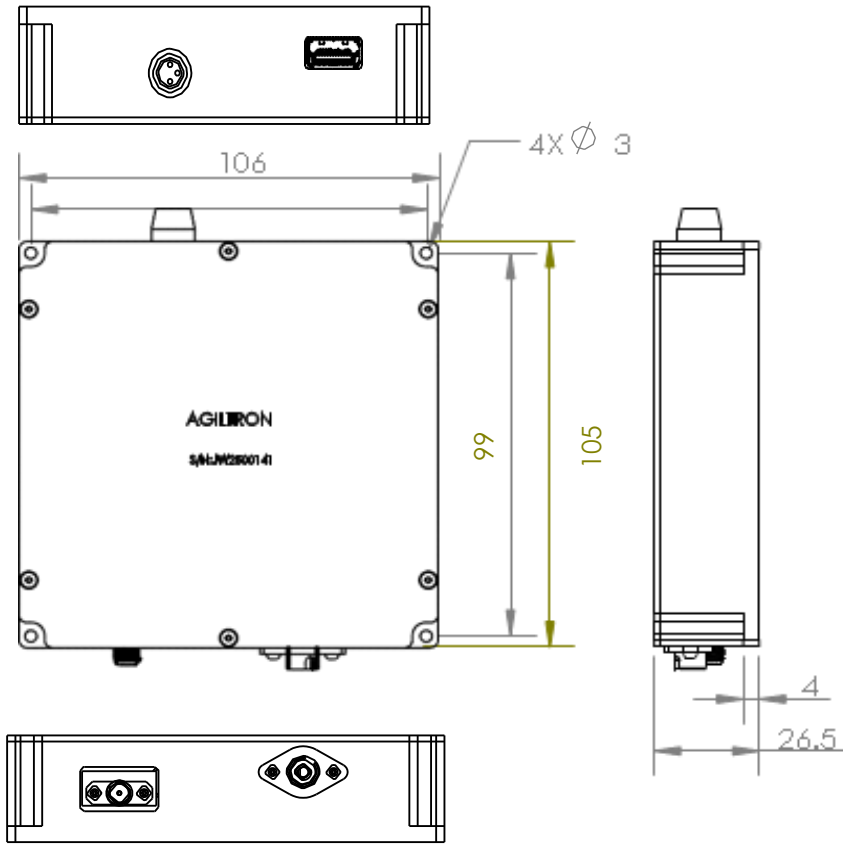

*Product dimensions may change without notice. This is sometimes required for non-standard specifications.

Ordering Information

Prefix	RF Frequency	Laser Wavelength	Tunable Laser	Package	RF Amplifier	Fiber Connector
LNTM-	14GHz = 1 30GHz = 3 40GHz = 4	1551.11 nm = 55111 1562.22 nm = 56222 External Laser = 00000	None = 1 Yes = 2	Module = 1 Special = 0	Non = 1 >20dBm = 2	FC/APC = 2 Special = 0

Lithium Niobate Modulator Transmitter Module 14 GHz

4 operation modes, up to 40 mW



DATASHEET

Typical S21 and S11 Bandwidth

